



PLASTIC SOUND-INSULATED FAN



EN

inWave
inWave EC

User's manual

CONTENTS

Overall dimensions.....	8
Delivery set.....	9
Brief description	9
Operation guidelines	9
Designation key	10
Technical data.....	11
Mounting.....	12
Electronics operation algorithm	18
Technical maintenance.....	21
Troubleshooting.....	22
Storage and transportation regulations.....	23
Manufacturer's warranty	24

This user's manual is a main operating document intended for technical, maintenance, and operating staff.

The manual contains information about purpose, technical details, operating principle, design, and installation of the inWave (EC) unit and all its modifications.

Technical and maintenance staff must have theoretical and practical training in the field of ventilation systems and should be able to work in accordance with workplace safety rules as well as construction norms and standards applicable in the territory of the country.

This unit is not intended for use by persons (including children) with reduced physical, sensory or mental capabilities, or lack of experience and knowledge, unless they have been given supervision or instruction concerning use of the unit by a person responsible for their safety.

Children should be supervised to ensure that they do not play with the unit.

This appliance can be used by children aged from 8 years and above and persons with reduced physical, sensory or mental capabilities or lack of experience and knowledge if they have been given supervision or instruction concerning use of the appliance in a safe way and understand the hazards involved.

Cleaning and user maintenance shall not be done by children without supervision.

Children shall not play with the appliance.

Connection to the mains must be made through a disconnecting device, which is integrated into the fixed wiring system in accordance with the wiring rules for design of electrical units, and has a contact separation in all poles that allows for full disconnection under overvoltage category III conditions.

If the supply cord is damaged, it must be replaced by the manufacturer, its service agent, or similarly qualified persons in order to avoid a safety hazard.

Ensure that the unit is switched off from the supply mains before removing the guard.

Precautions must be taken to avoid the back-flow of gases into the room from the open flue of gas or other fuel-burning appliances.

The appliance may adversely affect the safe operation of appliances burning gas or other fuels (including those in other rooms) due to back flow of combustion gases. These gases can potentially result in carbon monoxide poisoning. After installation of the unit the operation of flued gas appliances should be tested by a competent person to ensure that back flow of combustion gases does not occur.

Do not attach the product to the support using glue or adhesives. Use only the fastening method specified in the "User's manual".

All operations described in this manual must be performed by qualified personnel only, properly trained and qualified to install, make electrical connections and maintain ventilation units.

Do not attempt to install the product, connect it to the mains, or perform maintenance yourself.

This is unsafe and impossible without special knowledge.

Disconnect the power supply prior to any operations with the unit.

All user's manual requirements as well as the provisions of all the applicable local and national construction, electrical, and technical norms and standards must be observed when installing and operating the unit.

Disconnect the unit from the power supply prior to any connection, servicing, maintenance, and repair operations.

Connection of the unit to power mains is allowed by a qualified electrician with a work permit for the electric units up to 1000 V after careful reading of the present user's manual.

Check the unit for any visible damage of the impeller, the casing, and the grille before starting installation. The casing internals must be free of any foreign objects that can damage the impeller blades.

While mounting the unit, avoid compression of the casing!

Deformation of the casing may result in motor jam and excessive noise.

Misuse of the unit and any unauthorised modifications are not allowed.

Transported air must not contain any dust or other solid impurities, sticky substances, or fibrous materials.

Do not use the unit in a hazardous or explosive environment containing spirits, gasoline, insecticides, etc.

Do not close or block the intake or extract vents in order to ensure the efficient air flow.

Do not sit on the unit and do not put objects on it.

The information in this user's manual was correct at the time of the document's preparation.

The Company reserves the right to modify the technical

characteristics, design, or configuration of its products at any time in order to incorporate the latest technological developments.

Never touch the unit with wet or damp hands.

Never touch the unit when barefoot.

Do not install or use the product until all construction and finishing work has been completed in the room where it is to be installed.

BEFORE INSTALLING ADDITIONAL EXTERNAL DEVICES, READ THE RELEVANT USER MANUALS.



**THE PRODUCT MUST BE DISPOSED SEPARATELY AT THE END OF ITS SERVICE LIFE.
DO NOT DISPOSE THE UNIT AS UNSORTED DOMESTIC WASTE.**

OVERALL DIMENSIONS

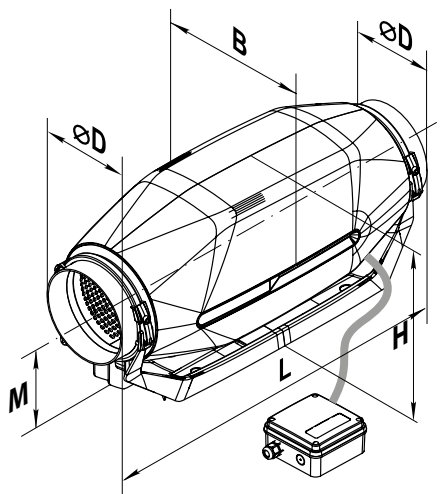

inWave (EC) 100/125 ($\varnothing 100$)

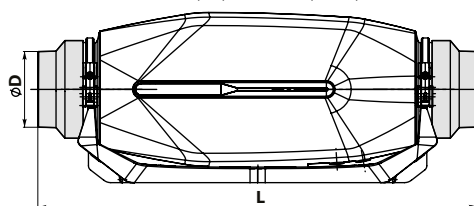

inWave (EC) 100/125 ($\varnothing 125$)

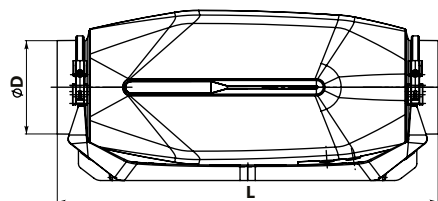

	$\varnothing D$	L	B	H	M
inWave (EC) 100/125	100	579	207	224	123
	125	502			

DELIVERY SET

Fan – 1 pc.
Screws and dowels – 8 pcs.
User's manual – 1 pc.
Packing box – 1 pc.

BRIEF DESCRIPTION

The product described herein is a plastic sound-insulated fan for supply or extract ventilation of premises.
The fan is connected to the \varnothing 100, 125 mm air ducts.

OPERATION GUIDELINES

The unit is designed for connection to power mains with the parameters specified in the «Technical data» section.
The fan is rated for continuous operation.
Air motion direction in the system must match the pointer on the fan casing.
The inWave (EC) unit is rated as a Class II.
Ingress protection rating against access to hazardous parts and water ingress is IPX4.
The fan is rated for operation at the ambient temperature ranging from +1 °C up to +40 °C.

DESIGNATION KEY

inWave EC 100 US



Options:

T: timer;

G1: speed controller with electronic thermostat and external temperature sensor mounted on a 4 m long cord. Algorithm of operation by temperature;

FR1: smooth speed controller from 0 to 100 % and power cord with a mains plug;

W: power cord with mains plug;

US: speed switch.

Spigot diameter [mm]

Electric motor type

_: asynchronous

EC: electronically commutated

Plastic sound-insulated fan

TECHNICAL DATA



To comply with the ErP 2018 regulation, a local demand controller and speed controller must be used.

MOUNTING

The fan is suitable both for horizontal or vertical mounting on the floor, on the wall or on the ceiling. The fan can be installed independently or as part of a set with parallel or in-series connection.

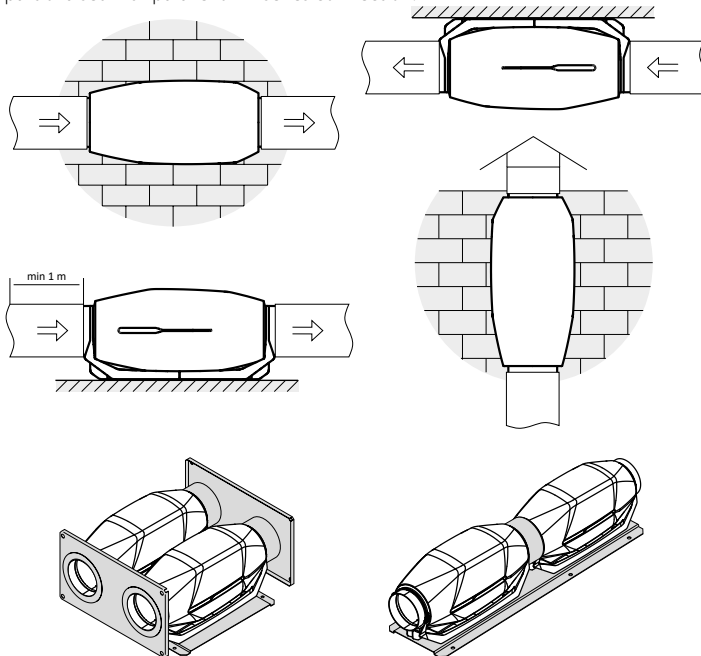

The diameter of the spigots in the inWave (EC) 100/125 model can be changed using adapters.

On outlet (discharge) spigot side it is necessary to install:

- in case of horizontal installation – a duct with a length of at least 1 m;
- in case of vertical installation – a canopy preventing moisture from getting into the fan.

The outlet spigot must always be connected to the air duct.

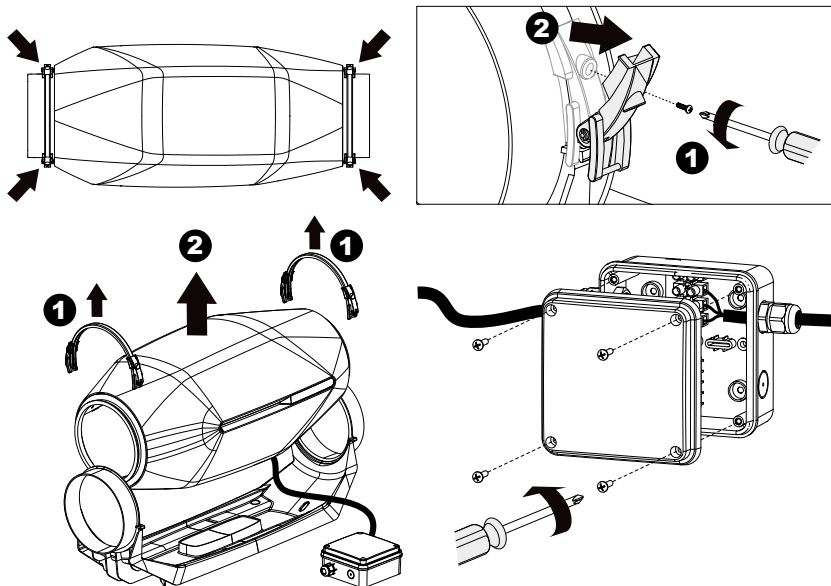

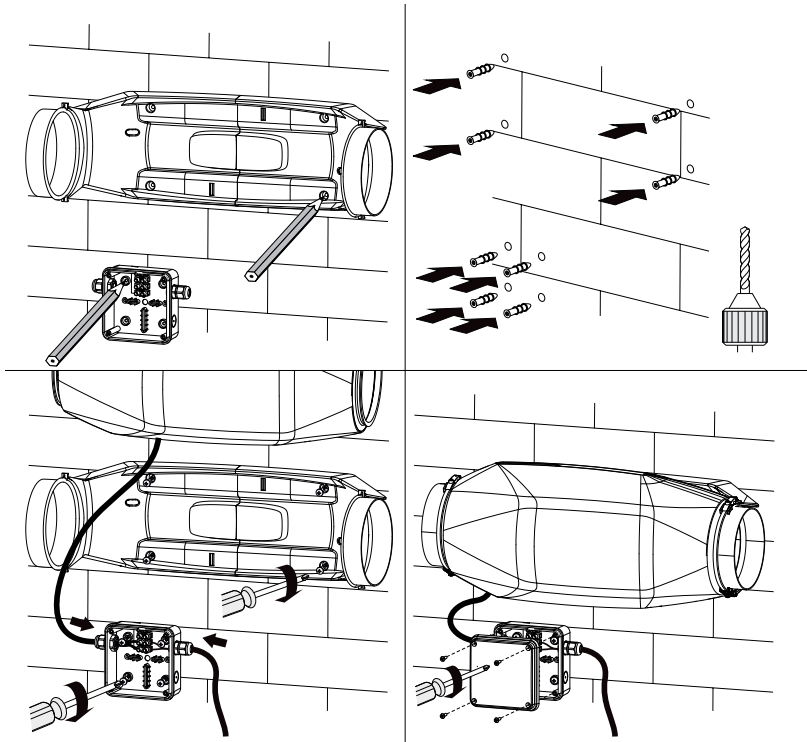

The fan wiring diagrams

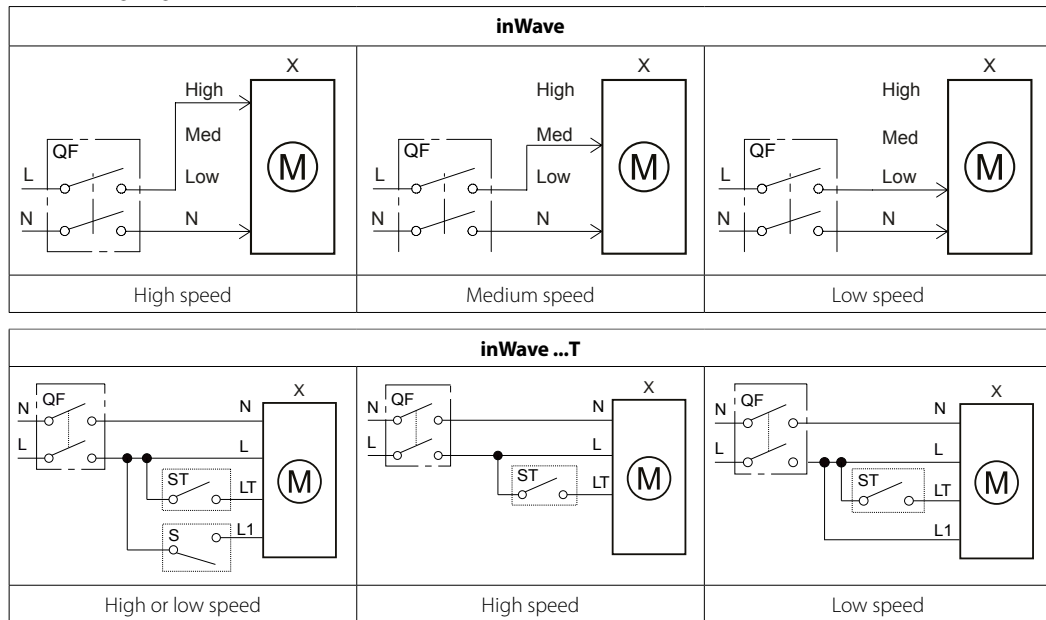

Designations on diagrams:

L – line; N – neutral; LT – external switch terminal; L1 – minimum speed terminal; High – maximum speed terminal; Med – medium speed terminal; Low – minimum speed terminal; QF – automatic circuit breaker; S – external speed switch; ST – external switch (for example, a light switch); X – input terminal.

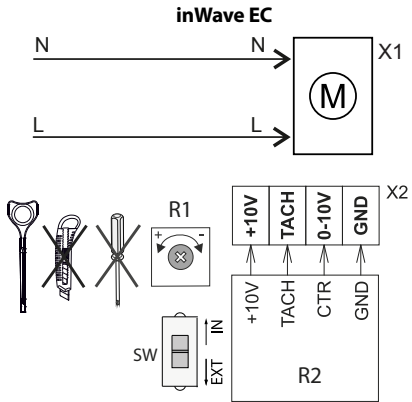

Designations on diagrams:

N — neutral

L — line

R1 — internal speed controller

R2 — external speed controller

SW — DIP switch



**WARNING! ONLY CONNECT THE POWER SUPPLY TO THE FAN AND EXTERNAL CONTROL DEVICE
WHEN THE MAINS VOLTAGE HAS BEEN DISCONNECTED**

inWave (EC) T

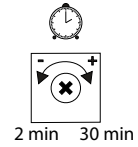
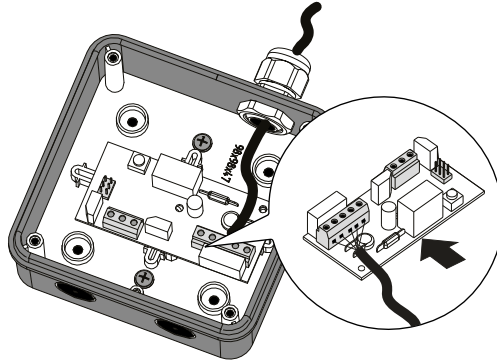

inWave EC

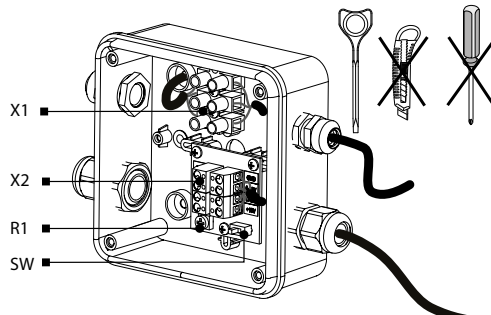

ELECTRONICS OPERATION ALGORITHM

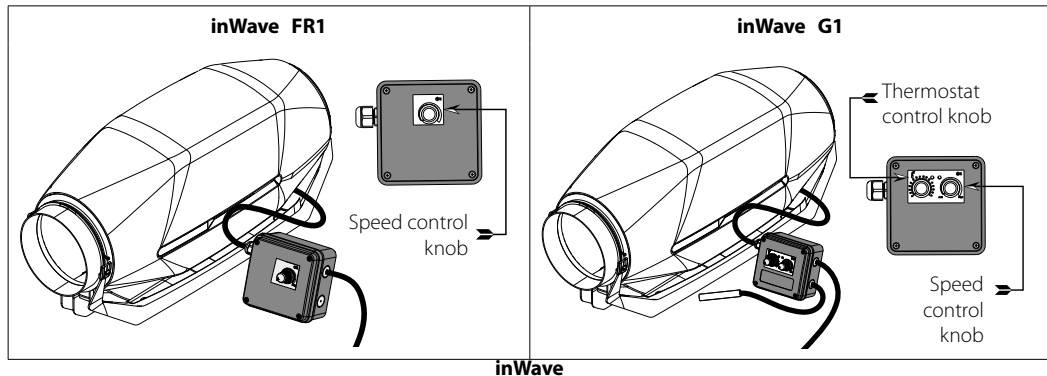

The fan speed without options can be controlled by voltage, as well as by thyristor controllers. A speed controller can be purchased separately.

Warning! When adjusting the voltage, ensure that there is no unusual noise or vibration at reduced motor speed. When adjusting the voltage, the motor current may exceed the rated current. The fan is equipped with a thermal switch without self-reset.

Probable causes of the thermal switch tripping:

- non-compliance with the operating rules
- impeller jamming (clean the impeller)
- motor malfunction (turn off the unit, contact the Seller)

To reset the thermostat:

- Switch off the power supply.
- Find and eliminate the cause of overheating.
- Switch the power back on.

The **inWave T** fan activates upon control voltage application to the LT input terminal by the external switch (e.g. indoor light switch). After the control voltage is off, the fan continues to operate within the set time period adjustable from 2 to 30 min by the timer.

To adjust the fan turn-on delay time, turn the control knob T clockwise to increase and counter-clockwise to decrease the turn-on delay time respectively.

WARNING! The timer circuit is live! Disconnect the fan from power supply prior to any adjustment operations.

The fan delivery set includes a specially designed plastic screwdriver for fan settings adjustments.

Use it to change the turn-off delay time and the humidity set point.

Do not use a metal screwdriver, knife, etc. for adjustment operations not to damage the circuit board.

The **inWave G1** fan is equipped with a TSC electronic module (speed controller with an electronic thermostat) for automatic speed control (air flow) depending on the air temperature.

The terminal compartment incorporates 2 control knobs:

- presetting speed;
- setting electric thermostat threshold value.

This indicator lights when the air temperature exceeds the set value.

To set the thermostat threshold, rotate the thermostat control knob clockwise to increase or counter-clockwise to decrease the temperature set point accordingly.

To set the fan speed (air capacity), rotate the speed control knob in the same way.

The fan operating logic may be based on temperature or timer indications:

As the air temperature drops 2 °C below the set point or if the initial temperature is below the set point, the fan operates with the set speed.

The **inWave FR1** fan is equipped with a speed controller that enables switching the fan on/off and smooth speed (air flow) regulation from minimum to maximum value.

inWave EC

The **EC** motor is controlled by sending of an external control signal from 0 to 10 V to the X2 terminal block or by the R1 internal speed controller. Control method selection is carried out by means of the SW DIP switch:

- DIP switch in IN position. The control signal is set by the R1 internal speed controller that enables switching the fan on/off and smooth speed (air flow) regulation from minimum to maximum value. Rotations are controlled from the minimum (extreme right position) to the maximum (extreme left position). When rotating counter-clockwise, the rotations increase.
- DIP switch in EXT position. The control signal is set by the R2 external control unit.



**DO NOT USE A METAL SCREWDRIVER, KNIFE, ETC. FOR ADJUSTMENT
OPERATIONS NOT TO DAMAGE THE CIRCUIT BOARD**

TECHNICAL MAINTENANCE

The fan surfaces must be regularly cleaned (once in 6 months) from dirt and dust. Disconnect the fan from power mains prior to any maintenance operations. To clean the fan, use a soft cloth or a brush wetted in a mild detergent solution. Do not allow water or liquid come into contact with electric components. Wipe the surfaces dry after cleaning.

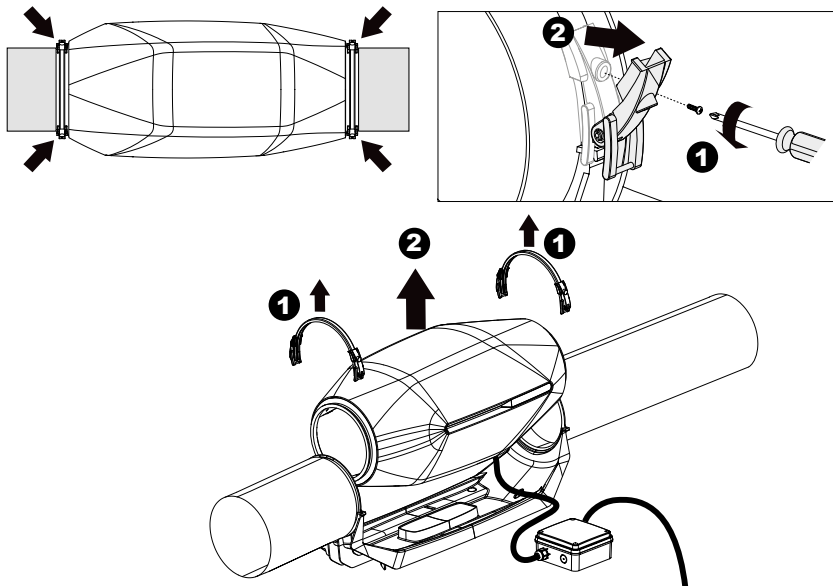

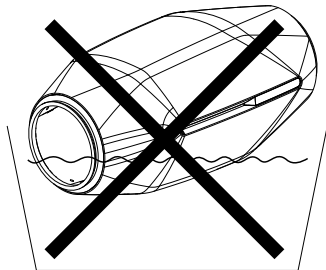
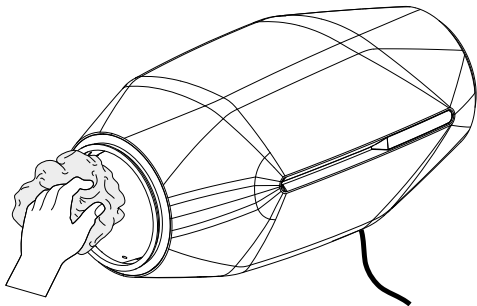

TROUBLESHOOTING

Problem	Possible reasons	Troubleshooting
When the unit is connected to power mains, the fan does not rotate and does not respond to any controls.	No power supply.	Make sure the power supply line is connected correctly, otherwise troubleshoot a connection error.
	Internal connection fault.	Contact the Seller.
Low air flow.	The ventilation system is clogged.	Clean the ventilation system.
Increased noise, vibration.	The impeller is clogged.	Clean the impeller.
	The fan is not secured well or is not mounted properly.	Troubleshoot the installation error.
	The ventilation system is clogged.	Clean the ventilation system.

STORAGE AND TRANSPORTATION REGULATIONS

- Store the unit in the manufacturer's original packaging box in a dry closed ventilated premise with temperature range from +5 °C to +40 °C and relative humidity up to 70 %.
- Storage environment must not contain aggressive vapors and chemical mixtures provoking corrosion, insulation, and sealing deformation.
- Use suitable hoist machinery for handling and storage operations to prevent possible damage to the unit.
- Follow the handling requirements applicable for the particular type of cargo.
- The unit can be carried in the original packaging by any mode of transport provided proper protection against precipitation and mechanical damage. The unit must be transported only in the working position.
- Avoid sharp blows, scratches, or rough handling during loading and unloading.
- Prior to the initial power-up after transportation at low temperatures, allow the unit to warm up at operating temperature for at least 3-4 hours.

MANUFACTURER'S WARRANTY

The product is in compliance with EU norms and standards on low voltage guidelines and electromagnetic compatibility. We hereby declare that the product complies with the provisions of Electromagnetic Compatibility (EMC) Directive 2014/30/EU of the European Parliament and of the Council, Low Voltage Directive (LVD) 2014/35/EU of the European Parliament and of the Council and CE-marking Council Directive 93/68/EEC. This certificate is issued following test carried out on samples of the product referred to above.

The manufacturer hereby warrants normal operation of the unit for 24 months after the retail sale date provided the user's observance of the transportation, storage, installation, and operation regulations. Should any malfunctions occur in the course of the unit operation through the Manufacturer's fault during the guaranteed period of operation, the user is entitled to get all the faults eliminated by the manufacturer by means of warranty repair at the factory free of charge. The warranty repair includes work specific to elimination of faults in the unit operation to ensure its intended use by the user within the guaranteed period of operation. The faults are eliminated by means of replacement or repair of the unit components or a specific part of such unit component.

The warranty repair does not include:

- routine technical maintenance
- unit installation/dismantling
- unit setup

To benefit from warranty repair, the user must provide the unit, the user's manual with the purchase date stamp, and the payment paperwork certifying the purchase. The unit model must comply with the one stated in the user's manual. Contact the Seller for warranty service.

The manufacturer's warranty does not apply to the following cases:

- User's failure to submit the unit with the entire delivery package as stated in the user's manual including submission with missing component parts previously dismounted by the user.
- Mismatch of the unit model and the brand name with the information stated on the unit packaging and in the user's manual.
- User's failure to ensure timely technical maintenance of the unit.
- Damage to the unit casing and internal components caused by the user.
- Redesign or engineering changes to the unit.

- Replacement and use of any assemblies, parts and components not approved by the manufacturer.
- Unit misuse.
- Violation of the unit installation regulations by the user.
- Violation of the unit control regulations by the user.
- Unit connection to power mains with a voltage different from the one stated in the user's manual.
- Unit breakdown due to voltage surges in power mains.
- Discretionary repair of the unit by the user.
- Unit repair by any persons without the manufacturer's authorization.
- Expiration of the unit warranty period.
- Violation of the unit transportation regulations by the user.
- Violation of the unit storage regulations by the user.
- Wrongful actions against the unit committed by third parties.
- Unit breakdown due to circumstances of insuperable force (fire, flood, earthquake, war, hostilities of any kind, blockades).
- Missing seals if provided by the user's manual.
- Failure to submit the user's manual with the unit purchase date stamp.
- Missing payment paperwork certifying the unit purchase.



FOLLOWING THE REGULATIONS STIPULATED HEREIN WILL ENSURE A LONG AND TROUBLE-FREE OPERATION OF THE UNIT



USER'S WARRANTY CLAIMS SHALL BE SUBJECT TO REVIEW ONLY UPON PRESENTATION OF THE UNIT, THE PAYMENT DOCUMENT AND THE USER'S MANUAL WITH THE PURCHASE DATE STAMP

Quality Inspector's Stamp _____

inWave _____

Seller _____

(name and stamp of the seller)

Purchase Date _____

Manufacturer: Ventilation Systems LLC,
Ukraine, Kyiv, 1 M. Kotsyubynskoho Street

Address of production facilities:
Ukraine, Kyiv Region, Fastiv District, Boyarka, 36 Sobornosti Street

