



## Centro-M EC 100

Centrifugal inline fans with EC-motors

- Impeller type: Centrifugal impeller with backward curved blades
- Casing material: Galvanized steel
- Installation in any position

	Unit of measurement	Centro-M EC 100
Phases	-	1
Minimum supply voltage	V	230
Maximum supply voltage	V	230
Power supply frequency	Hz	50/60
Maximum airflow	m <sup>3</sup> /h	345
Weight	kg	2.7
Transported air temperature (max)	°C	60
Transported air temperature (min)	°C	-25
Ingress protection rating	-	IPX4
Ingress protection rating of the drive	-	IP44
Impeller material	-	Plastic

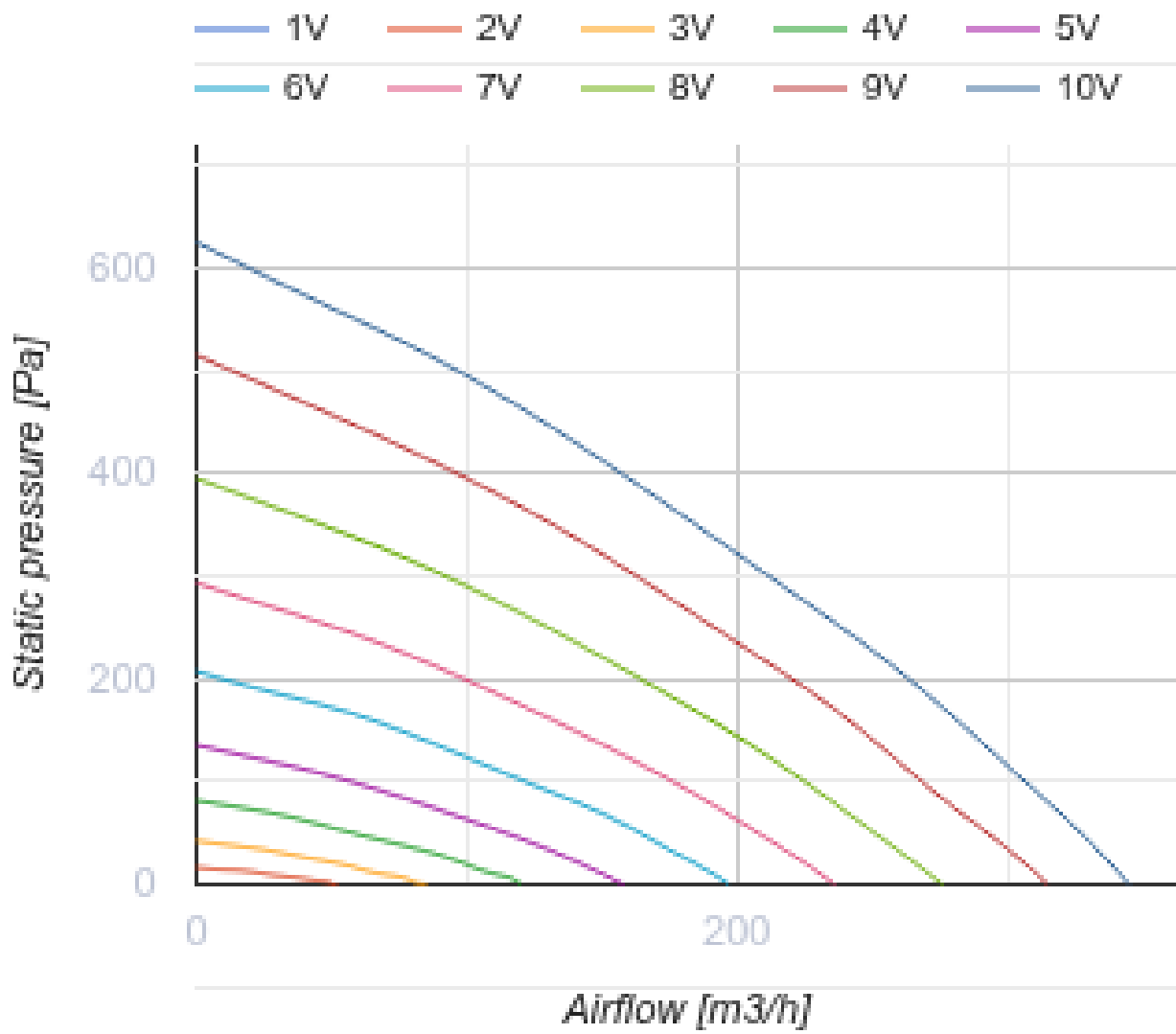

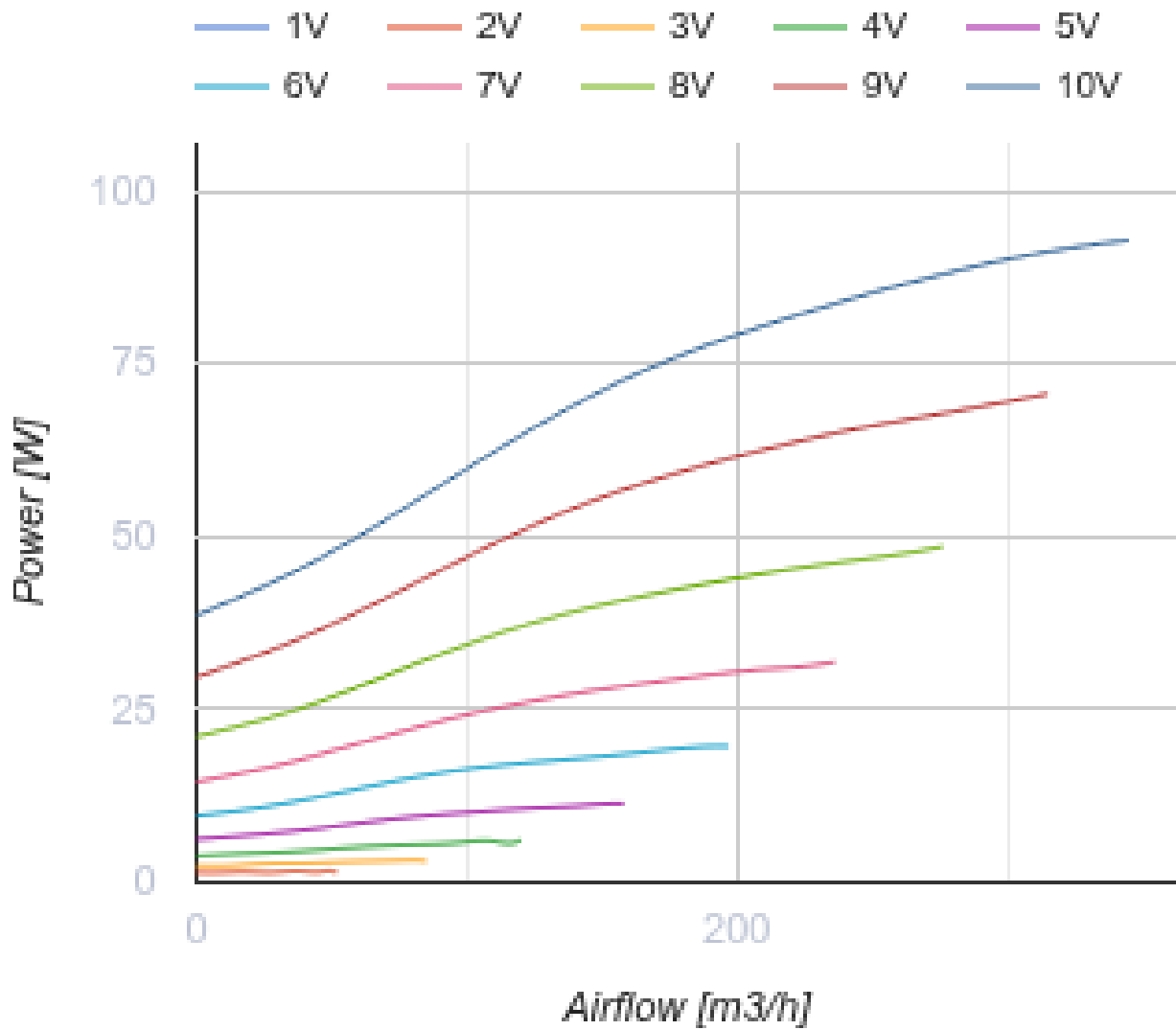

## Dimensions

Ø D	Ø D1	B	B1	L	L1	L2	L3	H
99	245	300	260	195	20	20	30	330

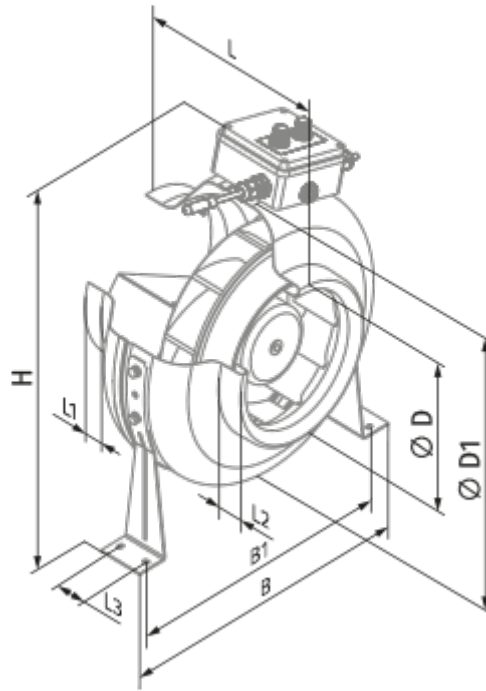



[K 100](#)



Clamp for round flexible ducts